

Strictly Confidential: (For Internal and Restricted use only)

Senior Secondary School Term II Examination, 2022

Marking Scheme – BIOLOGY (SUBJECT CODE — 044)

(PAPER CODE — 57/3/2)

General Instructions: -





1. You are aware that evaluation is the most important process in the actual and correct assessment of the candidates. A small mistake in evaluation may lead to serious problems which may affect the future of the candidates, education system and teaching profession. To avoid mistakes, it is requested that before starting evaluation, you must read and understand the spot evaluation guidelines carefully.
2. **“Evaluation policy is a confidential policy as it is related to the confidentiality of the examinations conducted, Evaluation done and several other aspects. Its’ leakage to public in any manner could lead to derailment of the examination system and affect the life and future of millions of candidates. Sharing this policy/document to anyone, publishing in any magazine and printing in News Paper/Website etc may invite action under IPC.”**
3. Evaluation is to be done as per instructions provided in the Marking Scheme. It should not be done according to one’s own interpretation or any other consideration. Marking Scheme should be strictly adhered to and religiously followed. **However, while evaluating, answers which are based on latest information or knowledge and/or are innovative, they may be assessed for their correctness otherwise and marks be awarded to them. In class-X, while evaluating two competency based questions, please try to understand given answer and even if reply is not from marking scheme but correct competency is enumerated by the candidate, marks should be awarded.**
4. The Head-Examiner must go through the first five answer books evaluated by each evaluator on the first day, to ensure that evaluation has been carried out as per the instructions given in the Marking Scheme. The remaining answer books meant for evaluation shall be given only after ensuring that there is no significant variation in the marking of individual evaluators.
5. Evaluators will mark(\surd) wherever answer is correct. For wrong answer ‘X’ be marked. Evaluators will not put right kind of mark while evaluating which gives an impression that answer is correct and no marks are awarded. **This is most common mistake which evaluators are committing.**
6. If a question has parts, please award marks on the right-hand side for each part. Marks awarded for different parts of the question should then be totalled up and written in the left-hand margin and encircled. This may be followed strictly.
7. If a question does not have any parts, marks must be awarded in the left-hand margin and encircled. This may also be followed strictly.
8. If a student has attempted an extra question, answer of the question deserving more marks should be retained and the other answer scored out.
9. No marks to be deducted for the cumulative effect of an error. It should be penalized only once.

10. A full scale of marks 0-35 has to be used. Please do not hesitate to award full marks if the answer deserves it.
11. Every examiner has to necessarily do evaluation work for full working hours i.e. 8 hours every day and evaluate 30 answer books per day in main subjects and 35 answer books per day in other subjects (Details are given in Spot Guidelines). This is in view of the reduced syllabus and number of questions in question paper.
12. Ensure that you do not make the following common types of errors committed by the Examiner in the past:-
 - Leaving answer or part thereof unassessed in an answer book.
 - Giving more marks for an answer than assigned to it.
 - Wrong totalling of marks awarded on a reply.
 - Wrong transfer of marks from the inside pages of the answer book to the title page.
 - Wrong question wise totalling on the title page.
 - Wrong totalling of marks of the two columns on the title page.
 - Wrong grand total.
 - Marks in words and figures not tallying.
 - Wrong transfer of marks from the answer book to online award list.
 - Answers marked as correct, but marks not awarded. (Ensure that the right tick mark is correctly and clearly indicated. It should merely be a line. Same is with the X for incorrect answer.)
 - Half or a part of answer marked correct and the rest as wrong, but no marks awarded.
13. While evaluating the answer books if the answer is found to be totally incorrect, it should be marked as cross (X) and awarded zero (0) Marks.
14. Any unassessed portion, non-carrying over of marks to the title page, or totalling error detected by the candidate shall damage the prestige of all the personnel engaged in the evaluation work as also of the Board. Hence, in order to uphold the prestige of all concerned, it is again reiterated that the instructions be followed meticulously and judiciously.
15. The Examiners should acquaint themselves with the guidelines given in the Guidelines for spot Evaluation before starting the actual evaluation.
16. Every Examiner shall also ensure that all the answers are evaluated, marks carried over to the title page, correctly totalled and written in figures and words.
17. The Board permits candidates to obtain photocopy of the Answer Book on request in an RTI application and also separately as a part of the re-evaluation process on payment of the processing charges.

MARKING SCHEME
Senior Secondary School Examination TERM–II, 2022
BIOLOGY (Subject Code — 044)
[Paper Code — 57/3/2]

Maximum Marks : 35

Q. No.	EXPECTED ANSWER / VALUE POINTS	Marks
SECTION - A		
1.	(a)(i) A - Mortality/No. of deaths in population B - Natality/No. of births in population	½ + ½
	(ii) 1 bacteria per bacteria per hour $\left[\text{Growth rate} = \frac{2 \text{ million} - 1 \text{ million}}{1 \text{ million}} \right]$	1
	OR	
	(b) • Expanding, Age pyramid • The number of individuals in the ‘pre-reproductive’ age group is more than the ‘reproductive’ age group.	½ + ½ 1
		2
2.	• Sneezing, watery eyes, running nose, difficulty in breathing and any other symptom (any two)	½ + ½
	• Body produces IgE antibodies/ give exaggerated response to the antigens/release chemicals like histamine and serotonin from mast cells.	1
3.	(a) (i) <i>Cannabis sativa</i>	½
	(ii) Flower tops or inflorescences, leaves and resin (any two)	½ + ½
	(iii) Influences cardio vascular system	½
	OR	
	(b) Provide site for interaction of lymphocytes with the antigen, lymphocytes proliferate to become effector cells.	1 + 1
		2
4.	• Masses of bacteria associated with fungal filaments to form mesh like structures.	1
	• Consume major part of organic matter in the effluent / lower BOD significantly/reduces polluting potential .	1
5.	<i>In situ</i> conservation — conservation and protection of whole ecosystem and its biodiversity at all levels in their natural habitat.	

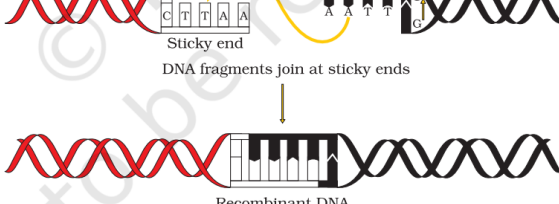
	<p>Whereas <i>Ex situ</i> conservation involves taking out the threatened animals and plants from their natural habitat and placed in special settings where they can be protected and given special care.</p> <p>*(Note- Give 2 marks if both the points are given correctly or no mark for any one correct point)</p>	2
		2
6.	<p>(i) Forms symbiotic association with roots of leguminous plants and helps in Nitrogen fixation</p> <p>(ii) Helps in Nitrogen fixation in aquatic or terrestrial environment and serves as biofertilizer / increases organic matter of soil.</p>	1 1 2
SECTION - B		
7.	<p>Restriction endonuclease cuts both DNA (vector and foreign DNA) at the same site (a little away from the centre of palindrome sites)</p> <p style="text-align: center;">↓</p> <p>Leaves single stranded portion at the ends of each DNA strand / formation of sticky ends on each DNA strand</p> <p style="text-align: center;">↓</p> <p>DNA fragments join at sticky ends by DNA ligase to form rDNA.</p> <p style="text-align: center;">//</p> <p style="text-align: center;">Action of Restriction enzyme</p> <div style="display: flex; justify-content: space-around;"> <div style="text-align: center;"> <p>The enzyme cuts both DNA strands at the same site</p> <p>Vector DNA</p>  </div> <div style="text-align: center;"> <p>EcoRI cuts the DNA between bases G and A only when the sequence GAATTC is present in the DNA</p> <p>Foreign DNA</p>  </div> </div> <p style="text-align: center;">↓</p> <div style="display: flex; justify-content: space-around;"> <div style="text-align: center;"> <p>Sticky end</p>  </div> <div style="text-align: center;"> <p>Sticky end</p>  </div> </div> <p style="text-align: center;">↓</p> <p style="text-align: center;">DNA fragments join at sticky ends</p> <div style="text-align: center;">  <p>Recombinant DNA</p> <p style="text-align: center;">//</p> </div>	1 1 1 // 1 1 1 //

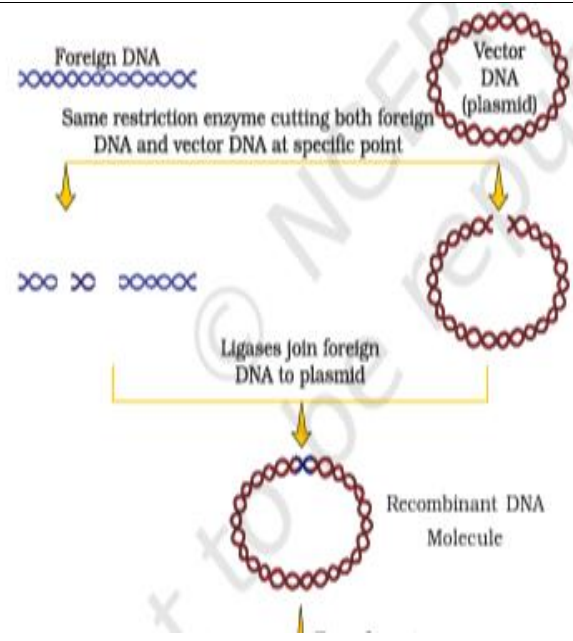
		1
		1
		1
		3
8.	<p>(a) Species richness increased with increasing explored area up to a limit</p> <p>(b) S = Species richness Z = Slope of the line / regression coefficient A = Area C = Y-intercept</p>	1
		$\frac{1}{2} \times 4$
		3
9.	<p>(a) (i) S (ii) R (iii) T</p> <p>(b) <ul style="list-style-type: none">● Process of cutting of separated bands of DNA , and extracting from the agarose gel.● Purified DNA is used in rDNA technology / genetic experiments.</p>	$\frac{1}{2} \times 3$
		$\frac{1}{2} + \frac{1}{2}$
		$\frac{1}{2}$
		3
10.	<p>(a) <ul style="list-style-type: none">● Contact inhibition—The property of normal cells by virtue of which contact with other cells inhibits their uncontrolled growth.● Normal cells do not grow any further till ‘in contact with other cells’, whereas cancerous cells lost this property and continue to divide to form tumor.</p> <p>(b) <ul style="list-style-type: none">● Destroys tumor● Activates the immune system of patients.</p>	1
		$\frac{1}{2} + \frac{1}{2}$
		$\frac{1}{2}$
		$\frac{1}{2}$
		3
11.	<ul style="list-style-type: none">● Toxic insecticidal proteins/ pro-toxin /crystal proteins produced by cry genes of <i>Bacillus thuringiensis</i>.● e.g., in Bt Cotton / Bt corn/rice / tomato/ soyabean(any other correct example of any crop or any insect)● Bt toxin protein exists as inactive protoxins, which get activated inside the	1
		$\frac{1}{2}$

<p>(iii) Early detection of diseases like cancer / AIDS/ genetic disorder, by amplification of desired genes (when very low concentration of bacteria or virus before setting of the disease symptoms).</p>	<p>$\frac{1}{2} + \frac{1}{2}$</p>
<p>OR</p>	
<p>(b) (i) Adenosine deaminase (ADA) deficiency.</p>	<p>1</p>
<p>(ii) ●Lymphocytes from the patient’s blood are grown in a culture medium outside the body</p>	<p>$\frac{1}{2}$</p>
<p>Using retroviral vector, a functional ADA cDNA, is introduced into these lymphocytes.</p>	<p>$\frac{1}{2} + \frac{1}{2}$</p>
<p>Modified lymphocytes injected back to the patient body.</p>	<p>$\frac{1}{2}$</p>
<p>●Lymphocytes are mortal / not immortal, the patient requires repeated/periodic infusion.</p>	<p>$\frac{1}{2} + \frac{1}{2}$</p>
<p>(iii) Gene is obtained from bone marrow cells producing ADA is introduced into cells at <u>early embryonic</u> stage.</p>	<p>1</p>
<p>5</p>	

* * *